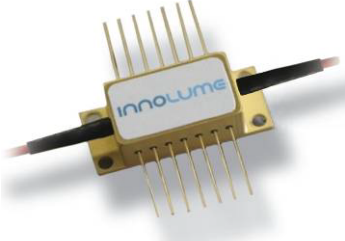

SOA-1060-20-PM-32dB	
High net gain Semiconductor Optical Amplifier	
	<p>Features:</p> <ul style="list-style-type: none"> High saturation output power Ultra high net gain Panda PM-fibers with FC/APC connectors Non PM fiber HI1060 available by request Integrated thermoelectric cooler and thermistor <p>Applications:</p> <ul style="list-style-type: none"> Swept Laser Source
<p>Specification for engineering samples</p>	<p>DATE: 31th March 2010</p>

SPECIFICATIONS				
Test conditions: thermistor temperature 25°C, CW operation mode				
Parameters	Min.	Typ.	Max.	Unit
Central wavelength	1050	1060	1070	nm
Optical bandwidth at -3dB from gain maximum (P _{IN} = -20dBm)	20	35		nm
Optical bandwidth at +20dB gain (P _{IN} = -20dBm)	50	55		nm
Small signal gain across bandwidth (P _{IN} = -20dBm)	32	35		dB
Saturation output power @ -3dB	16	21		dBm
Average ASE ripple amplitude @ I _{OP}		0.1	1*	dB
Operation current		400	600	mA
Forward voltage @ I _{OP}		1.8	2.0	V
Polarization Extinction Ratio (PER)	15	20		dB

* Lesser value on request

ABSOLUTE MAXIMUM RATINGS			
Parameters	Min.	Max.	Unit
SOA reverse voltage		2	V
SOA CW forward current		1000	mA
Thermo Electric Cooler current		3.0	A
Thermo Electric Cooler voltage		4.0	V
Storage temperature range	5	80	°C
Case operating temperature range	10	50	°C

THERMISTOR SPECIFICATION		
Parameters	Value	Unit
Thermistor type	BC103J1K	
Resistance @25°C	10 ± 0.5	kOhm
Beta 0-50°C	3890	K

R-T CURVE

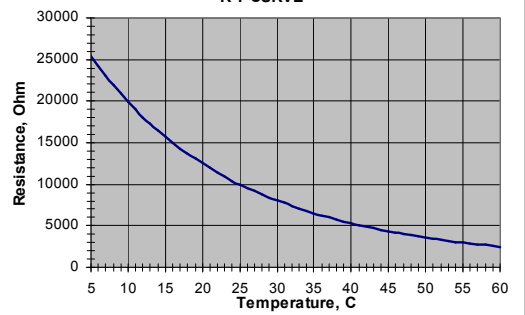

FIBER SPECIFICATION		
Parameters	PANDA PM980	Unit
Mode-field diameter (at 1060nm)	6.6±1.0	µm
Cladding diameter	125±1	µm
Coating diameter	245±15	µm
Core-to-cladding offset	≤0.5	µm
Each fiber length	1.1 ± 0.2	m
Connector	FC/APC	

Connector alignment to Panda fiber:

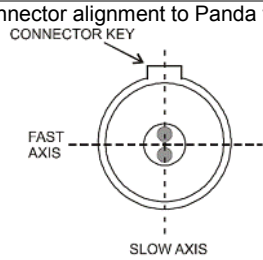

Typical Performance

ASE L-I-V CURVE
 (Test conditions: CW operation, 25°C)

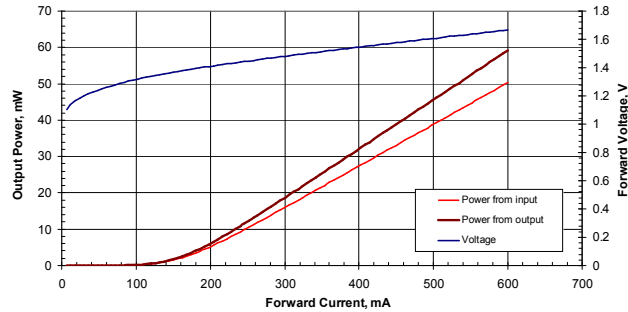

GAIN VALUE versus INPUT SIGNAL
 (Test conditions: CW operation, 400mA, 1060nm, 25°C)

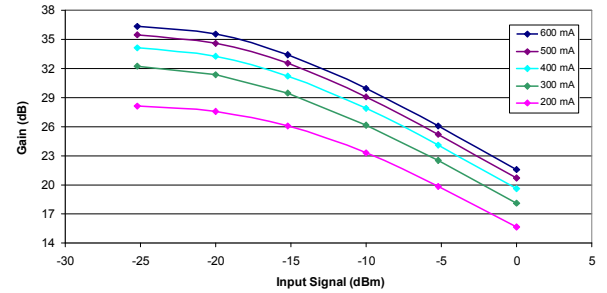

ASE SPECTRUM
 (Test conditions: CW operation, 400mA, 25°C)

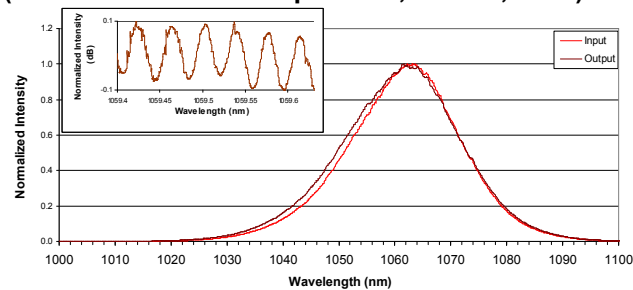

GAIN VALUE versus OUTPUT SIGNAL
 (Test conditions: CW operation, 400mA, 1060nm, 25°C)

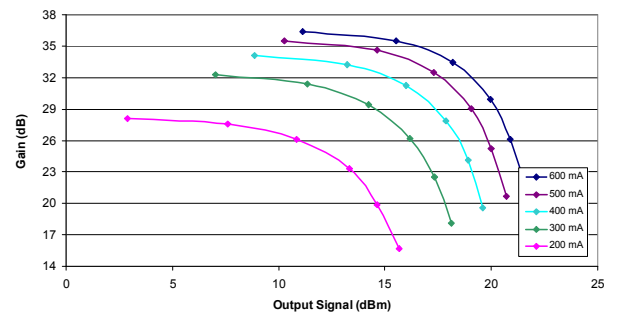

GAIN SPECTRA (Test conditions: CW operation, 400mA, 25°C)

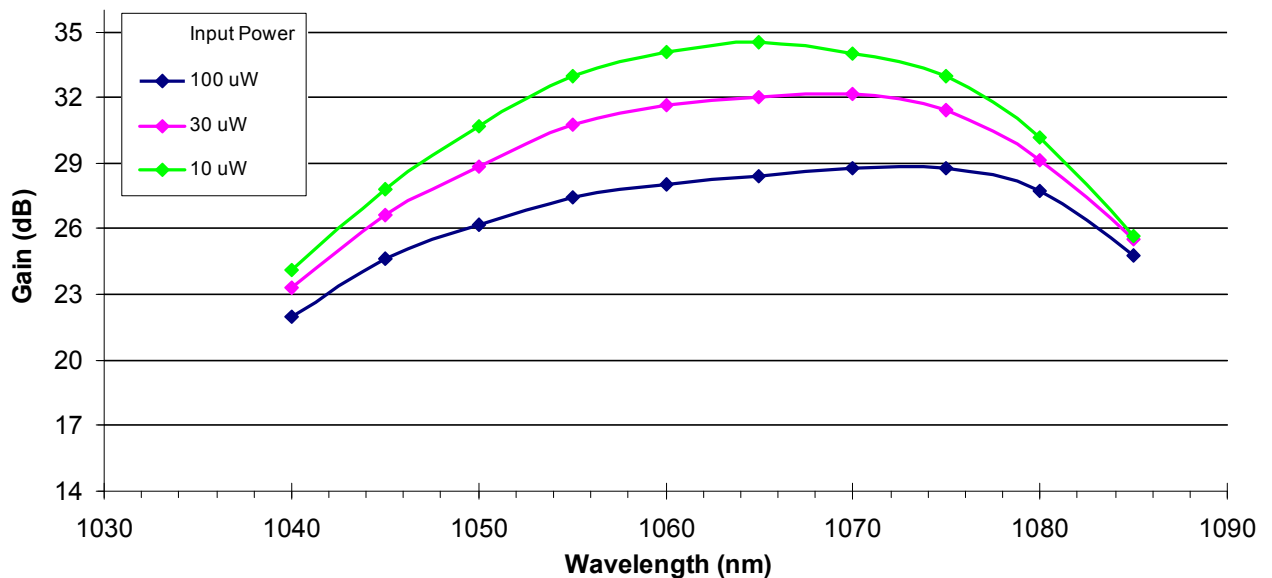

DIMENSIONS

All sizes in mm

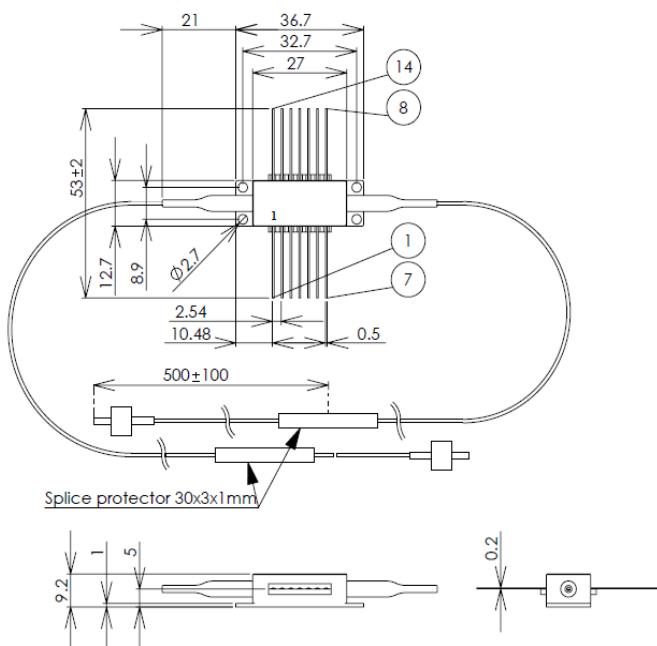

Pin connections:

Pin#	Description	Pin#	Description
1	TEC "+"	8	
2	Thermistor	9	
3		10	SOA anode (+)
4		11	SOA cathode (-)
5	Thermistor	12	
6		13	Case ground
7		14	TEC "-"

SAFETY AND OPERATING INSTRUCTIONS

The laser light emitted from this device is invisible and will be harmful to the human eye. Avoid looking directly into the output fiber or into the collimated beam along its optical axis when the device is in operation. Proper laser safety eyewear must be worn during operation.

Operating the SOA Module outside of its maximum ratings may cause device failure or a safety hazard. Power supplies used with the component must be employed such that the maximum peak optical power cannot be exceeded. A proper heatsink for the SOA Module is required. Exposure to maximum ratings for extended period of time or exposure above one or more max ratings may cause damage or affect the reliability of the device.

ESD PROTECTION – Electrostatic discharge is the primary cause of unexpected SOA chip failure. Take extreme precaution to prevent ESD. Use wrist straps, grounded work surfaces and rigorous antistatic techniques when handling laser diodes.

